



PUBLIC WORKS DEPARTMENT

MAYOR: Lauren McLean | DIRECTOR: Stephan Burgos



Public Works Solid Waste Design Standards (Policy 1) 2026

BOISE CITY HALL: 150 N. Capitol Boulevard | MAIL: P.O. Box 500, Boise, Idaho 83701-0500 | P: 208-608-7150 | TTY: 800-377-3529

BOISE CITY COUNCIL: Colin Nash (President), Meredith Stead (President Pro Tem), Kathy Corless, Jimmy Hallyburton, Jordan Morales, Luci Willits

CITYOFBOISE.ORG/PUBLICWORKS

Table of Contents

1. INTRODUCTION	3
2. SCOPE.....	3
3. COMMERCIAL SUBMITTAL REQUIREMENTS	4
4. EXTERIOR ENCLOSURE DESIGN.....	6
TABLE 1. EXTERIOR ENCLOSURE DESIGN SPECIFICATIONS	7
5. ACCESS REQUIREMENTS FOR EXTERIOR ENCLOSURES	8
6. INTERNAL SOLID WASTE ROOMS	10
TABLE 2. MINIMUM SOLID WASTE ROOM DESIGN SPECIFICATIONS	11
7. ALLEY SERVICE.....	12
8. LARGE CONTAINER AND LOADING DOCK	13
9. RESIDENTIAL PROPERTIES AND SUBDIVISIONS	14
10. WAIVERS AND APPEALS.....	15
12. DIAGRAMS	16
Figure 1 – 16' X 12' Enclosure, Single Dumpster with Two Carts.....	16
Figure 2 – 18' X 12' Exterior Enclosure – Two Dumpsters.....	17
Figure 3 – Typical Single-Bank Cart Corral	18
Figure 4 – Typical Double-Bank Cart Corral – 8 Carts.....	19
Figure 5 – Dual Dumpsters in Single Enclosures.....	20
Figure 6 – Typical Dumpster Enclosure, Bollard, and Pedestrian Entrance Location .	21
Figure 7 – Approved Turnaround Types.....	22
Figure 8 – Exterior Enclosure Access Examples.....	23
Figure 9a – Acceptable Site Multiple Enclosure Configuration.....	24
Figure 9b – Unacceptable Site Multiple Enclosure Configuration	25



1. INTRODUCTION

- 1.1.** This policy details requirements for commercial solid waste service and residential subdivisions, which will provide for the safe and efficient collection of solid waste materials. Public Works Solid Waste staff shall review and have final approval over safety factors and space requirements, including enclosure specifications, access to solid waste containers, and proper distance, height, and width clearances.
- 1.2.** These Solid Waste Design Standards align with the City of Boise's Climate Action Roadmap and Sustainable Materials Management goals by supporting waste diversion and reducing greenhouse gas emissions from collection operations. By requiring accessible, efficient infrastructure for trash and recycling, this policy helps ensure long-term operational success, provides consistent and reliable service and advances Boise's commitment to reducing waste.

2. SCOPE

- 2.1.** This policy applies to all commercial properties within the City of Boise which use commercial solid waste containers and service with scheduled collection, and new residential subdivisions.
- 2.2.** Exterior solid waste enclosures are required for all new commercial solid waste service locations except those sites with an approved internal room for solid waste storage, alley collection, or large compactors and/or roll off containers.
- 2.3.** Residential subdivisions are required to provide adequate maneuvering space for the collection vehicle and staging space if residential cart service is being used.
- 2.4.** Multi-family residential properties with four (4) or more residential dwelling units are considered commercial sites and will utilize commercial solid waste service.
- 2.5.** Collection for commercial properties occurs 24 hours per day on days of available service. Multi-family or mixed-use sites are designated as commercial under these standards and therefore, may be collected at any time during the service window. Noise is created during collection, please take this under consideration when designing the building and selecting the container location.
- 2.6.** Solid waste storage, screening, and staging plans will be required to be brought to current standards for:
 - 2.6.1.** Construction which impacts parking or driveway areas;



- 2.6.2.** Construction which restricts access to, modifies, or changes the location of an existing enclosure;
- 2.6.3.** Interior and exterior tenant improvements which change the use of the building.
- 2.7.** City of Boise Public Works Solid Waste staff have final approval on all compactor installations and can deny or require the use of compactors in projects that do not meet minimum Solid Waste Design Standards.

3. COMMERCIAL SUBMITTAL REQUIREMENTS

- 3.1.** All submittals for commercial projects shall include a scale drawing of the site, clearly showing:
 - 3.1.1.** Lot lines;
 - 3.1.2.** Existing and planned buildings;
 - 3.1.3.** All existing and planned sidewalks, curb cuts, drives, parking spaces, landscaping, freestanding signs, posts, poles (e.g., streetlight, telephone and electric poles), overhead and underground utilities, and other structures that may affect collection;
 - 3.1.4.** The location of all public rights-of-way, fire hydrants, sidewalks and public transportation stops on the premises and adjacent to the premises;
 - 3.1.5.** Adjacent structures, including distances to the nearest abutting residential areas;
 - 3.1.6.** Access roadways or drives intended for collection, ingress and egress, fire lanes, turnaround locations and vertical clearances; and
 - 3.1.7.** Proposed circulation path for the collection vehicles.
- 3.2.** For sites utilizing exterior solid waste enclosures, submittals shall include location and dimensions of all proposed solid waste enclosures and containers, and a detailed drawing of the proposed solid waste enclosure.
- 3.3.** For sites utilizing internal solid waste rooms, submittals shall include location and dimensions of the solid waste room and containers, and the location and dimensions of the staging area.
- 3.4.** For sites utilizing alleys or service drives, submittals shall include location of solid waste containers and dimensions of the alley or service drive.
- 3.5.** For sites utilizing individual carts for commercial service, submittals shall include labels showing the storage location of the containers and their staging area for day of service.



- 3.6.** All solid waste container storage locations for commercial, multi-family, and mixed-use developments shall be located internal to the site and not within the public right-of-way.
- 3.6.1.** This requirement excludes alley service, residential subdivisions, and existing or currently approved service arrangements by Public Works Solid Waste staff.
- 3.6.2.** Where internal siting is infeasible due to site constraints, alternate placement may be considered upon review and written approval by Public Works Solid Waste.
- 3.7.** For Cottage Courts and similar small-scale commercial multi-family developments that utilize individual cart service rather than dumpster enclosures:
- 3.7.1.** Cottage Courts are considered commercial sites and must comply with all commercial enclosure standards and site access submittal requirements.
- 3.7.2.** For developments where residents store carts at their dwelling unit, carts must be brought to the curbside for servicing, provided there is a minimum of 9' of curb space in front of their home, or brought to an approved intermediate staging area that has been approved by Public Works Solid Waste staff. Carts must be brought back to dwelling units within 24 hours of collection.
- 3.7.3.** Intermediate staging areas must be located internal to the site along a shared service drive. The service drive must be a minimum of 20' wide to accommodate cart staging. Carts must be staged in a row along the service drive. If carts are serviced via automated side-load vehicle, allow 5' per cart. If carts are serviced via carry-out, allow 3' per cart. Carts must be brought back to dwelling unit within 24 hours of collection.
- 3.7.4.** For developments where carts are shared amongst residents in a permanent location, exterior cart corral(s), located in an approved location and appropriately sized for the number of carts in accordance with Table 1, must be provided.
- 3.8.** For projects where standard design information cannot be provided such as those with mixed service types, multiple service types, or significant departures from these design standards, a Solid Waste Narrative, signed by the owner or property management, will be required at the discretion of Public Works Solid Waste staff.
- 3.9.** A Solid Waste Narrative must include the following elements:



- 3.9.1. Purpose and Site Description:** Briefly describe the project scope and the purpose of the narrative, including why standard design criteria cannot be met.
 - 3.9.2. Waste Generation Overview:** Identify the types and estimated quantities of waste streams expected (e.g., trash, recycling, glass, organics).
 - 3.9.3. Waste Management Practices:** Describe on-site storage strategy, container types and sizes, collection locations, access provisions, and collection frequency.
 - 3.9.4. Diversion and Recycling Strategies:** Outline waste diversion plans, including specific materials targeted for recycling, organics diversion, or reuse.
 - 3.9.5. Compliance with Standards and Ordinance:** Explain how the project will comply with applicable solid waste ordinances and align with the intent of these design standards.
 - 3.9.6. Roles and Responsibilities:** Identify responsible parties for waste management implementation, including staff oversight, equipment use, and service coordination.
- 3.10.** For sites that do not require solid waste service, submittals shall include an explanation stating why solid waste will not be collected at this site and how any accumulated waste will be stored, handled and transported to a licensed disposal site.

4. EXTERIOR ENCLOSURE DESIGN

- 4.1.** This section applies to all commercial properties with exterior enclosures where solid waste containers are stored in a walled structure located outside the building envelope, with one or more gates for access.
- 4.2.** The dimensions of the enclosure will depend on what types of containers are to be utilized. The following table details the required enclosure specifications for various solid waste containers available from the city's contracted waste hauler (see Table 1 below, and Figures 1 through 6)



TABLE 1. EXTERIOR ENCLOSURE DESIGN SPECIFICATIONS

Solid Waste Containers	Minimum Dimensions (Length and Width)	Enclosure Gates/Doors	Surface Pad w/ apron
Dumpster Enclosure			
One 3, 6, or 8-yard dumpster, and one grease container or up to two 95-gallon carts	16' X 12'	Must open at least 120 degrees, and have a mechanism to hold them in the open position	Minimum four-inch-thick reinforced concrete
Two dumpsters: 3, 6, or 8-yard	18' X 12'	Must open at least 120 degrees, and have a mechanism to hold them in the open position	Minimum four-inch-thick reinforced concrete
Two 3, 6, or 8-yard dumpsters and up to four 95-gallon carts	18' X 16'	Must open at least 120 degrees, and have a mechanism to hold them in the open position	Minimum four-inch-thick reinforced concrete
Three dumpsters: 3, 6, or 8-yard	27' X 12' with a 27' length gate opening or 30' x 12' with one 18' length gate opening and one 12' length gate opening.	Must open at least 120 degrees, and have a mechanism to hold them in the open position	Minimum four-inch-thick reinforced concrete
Cart Corral			
95-gallon carts* *Max of 12 carts allowed	Single bank – 3' length per cart X 4' width. (e.g. 4 carts = 12' X 4', 8 carts = 24' X 4') Double bank – 12' length with 4' per column and 4' middle pedestrian path X 3' width per cart. (e.g. 8 carts = 12' X 12', 12 carts = 12' X 18')	Use appropriately sized gate for enclosure or three-sided enclosure with no gate.	Paved and sized to fit enclosure.

- 4.3.** Multiple-dumpster enclosures designed with a partition or center gate post separating the dumpsters are treated as two separate enclosures for the purpose of determining minimum interior dimensions. For example, if a proposed enclosure contains two dumpsters with a separate gate opening for each container, they would be treated as separate single enclosures with 12' - length gate openings required for each (see Figure 5 at end).
- 4.4.** Multi-family residential or mixed-use properties utilizing 3-yard or larger containers must provide a minimum 3'-wide pedestrian entrance to the enclosure separate from the gate access used for the collection vehicle (see Figure 6 at end).
- 4.5.** Wheeled carts and dumpsters may be brought to the curb or intermediate staging area by building staff prior for scheduled collection. Carts and dumpsters must then be returned to their storage location within 24 hours by building staff or the carts may be removed.
- 4.6.** Solid waste enclosures may not be used for storage of any other materials except solid waste, and all waste must be stored within the provided container(s).
- 4.7.** If bollards are placed inside the enclosure to protect the back wall, they must be located at least 9' back from the enclosure gate opening. Bollards cannot be placed within or near an enclosure in such a way as to restrict dimensions of the gate opening (see Figure 6 at end).
- 4.8.** Solid waste containers must be shielded from public view by a minimum 4' high fence for cart corrals, or 6' high fence or wall, and enclosure gate for dumpster enclosures.

5. ACCESS REQUIREMENTS FOR EXTERIOR ENCLOSURES

- 5.1.** Enclosures must be located and configured so there is at least 50' of unobstructed access in front of the enclosure as measured from the center of the enclosure gates, extending to the length of the enclosure gates (see Figures 1 and 2 at end).
- 5.2.** The site plan must be designed so that backing movements of the collection vehicle do not exceed 70' in length, measured from the front of the enclosure to the closest edge of an intersecting drive aisle or paved area where the vehicle can turn around. Additionally, all backing must be in a straight line; vehicles cannot perform turning maneuvers while backing unless in an approved protected turnaround area.



- 5.3.** There must be a vertical clearance of 25' above and 30' in front of all exterior enclosures to avoid damage and interference while containers are being emptied.
- 5.4.** If a collection vehicle cannot exit a site by continuing forward to a public street after completing service, the site must provide one of the following approved paved turnaround types:
 - 5.4.1.** A 120' hammerhead turnaround, with each leg a minimum of 20' wide and 60' long, or
 - 5.4.2.** A 96' diameter cul-de-sac, measured edge-to-edge of pavement with no center island, or
 - 5.4.3.** An acceptable alternative turnaround configuration approved by Public Works Solid Waste staff, such as:
 - 5.4.3.1.** A modified hammerhead design of minimum 70' in length (measured from the centerline of the access drive to the back edge of pavement), with a minimum 20'-wide leg.
- 5.5.** All turnaround designs must:
 - 5.5.1.** Be constructed of paved surface suitable for vehicles with a gross vehicle weight (GVW) of 75,000 lbs.
 - 5.5.2.** Allow for full turning movement of front-loading and side-loading solid waste vehicles, as applicable.
 - 5.5.3.** Always remain unobstructed by parking or storage and be signed or striped appropriately.
- 5.6.** Adequate maneuvering room for a collection vehicle with an overall approximate length of 35' and a 48' minimum outside turning radius must be provided. Separate site plans detailing the proposed collection vehicle drive path may be required for projects with limited paved maneuvering areas.
- 5.7.** All private roads, alleys, or service drives must provide an unobstructed path at least 15' high and 16' wide, unless in an approved turnaround zone, to allow for safe access to enclosures.
- 5.8.** The area 40' in front of the enclosure may not have a slope of greater than 4%
- 5.9.** Access to enclosures must be maintained by the property owner by keeping path to the enclosure free of accumulating snow, parked cars, debris or any other obstacle obstructing access.
- 5.10.** Enclosures located behind security gates or locked gates must be made accessible to the collection vehicles during service hours.



- 5.11.** The following cases require a legal agreement signed by all affected parties to be submitted to the Public Works Solid Waste, with one entity to be responsible for service billing:
- 5.11.1.** Two or more adjacent properties opting to share a dumpster enclosure, where feasible and approved by Public Works Solid Waste staff.
 - 5.11.2.** An enclosure with collection vehicle access located on an adjacent property with separate ownership.
- 5.12.** If a property has more than one enclosure in a designated area, enclosures must be placed in such a way that collection vehicles do not have to leave the site to service the enclosures (see Fig. 9). This can be achieved by:
- 5.12.1.** Positioning the enclosures so that collection vehicles can remain on-site to service them. Or,
 - 5.12.2.** Designing designated space for the collection vehicles to turn around on-site.

6. INTERNAL SOLID WASTE ROOMS

- 6.1.** This section applies to commercial properties where solid waste containers are stored in an enclosed room within a building and brought out to a solid waste staging area.
- 6.2.** All internal solid waste rooms must:
- 6.2.1.** Be located on surface level, or in underground or above ground-level garage areas, with adequate overhead clearances for the collection vehicle and container types.
 - 6.2.2.** Provide an 8'-wide paved access ramp sloped towards the staging/service area or alley/service drive within 15' of the solid waste room exterior door. Access ramp may not have a slope greater than 4%, no curbs, rolled curbs, or pavement gaps may obstruct movement of containers to the street are permitted.
 - 6.2.3.** Service containers are limited to 3 – 5-yard wheeled dumpsters or 95-gallon carts, or approved containers and compactors where feasible.
 - 6.2.4.** Provide a minimum of 15' overhead clearance. If containers are serviced within the building envelope, a minimum 25' overhead clearance must be provided.
 - 6.2.5.** Not be located within 20' of an intersection as measured from the center of the internal solid waste room door.



- 6.3.** If servicing solid waste room from a parking lot, private service drive; Provide a staging/service area for the solid waste containers in front of the access ramp, with minimum dimensions of 20' along the curb and 9' out from the curb. This area must be marked with appropriate signage stating, "No parking or loading." Public Works Solid Waste staff shall have final approval on the location and design of this staging/service area.
- 6.4.** If alley access is unavailable or the building occupies the entire site, the city may require solid waste service to be located within the building envelope, including vehicle access with the following minimum clearances:
 - 6.4.1.** 15 feet vertical clearance for internal travel lanes
 - 6.4.2.** 26 feet vertical clearance at the point of service (where containers are emptied)
 - 6.4.3.** Final clearance depends on truck type to be determined during review.
- 6.5.** Required dimensions for solid waste rooms are detailed in the following table (Table 2).

TABLE 2. MINIMUM SOLID WASTE ROOM DESIGN SPECIFICATIONS

Non-Residential Development Area*	Minimum Area of Solid Waste Room	Roll up Door Opening Dimension
0—5,000 square feet	192 square feet (16' X 12')	8ft length door
5,001—20,000 square feet	256 square feet	10ft length door
20,001—50,000 square feet	320 square feet	10ft length door
50,001—100,000 square feet	480 square feet	12ft length door
100,001—200,000 square feet	575 square feet	12ft length door
200,001+	Every additional 25,000 square feet shall require an additional 72 square feet of storage space	16ft length door

Multi-family Development Number of Units	Minimum Area of Solid Waste Room	Roll up Door Opening Dimension
4-12 Dwelling Units	192 square feet (16 X 12)	8ft length door
13-24 Dwelling Units	256 square feet	10ft length door
25-50 Dwelling Units	320 square feet	10ft length door
51-100 dwelling units	480 square feet plus 4 square feet for each additional unit above 50 units	12ft length door
More than 100 dwelling units	680 square feet plus 4 square feet for each additional unit above 100 units.	12ft length door or 16ft length door to reduce depth of room.

- 6.6.** If project is mixed-use, utilize Multi-family Development minimum dimensions plus 50% of Non-Residential Development Area minimums. Developments with Restaurant or Food Service uses may be required to have additional space up to 100% of Non-Residential minimum area.
- 6.7.** For developments that utilize compactor units, the required minimum storage space square footage may be reduced up to 25%.
- 6.8.** No other equipment or materials may be stored in solid waste rooms.
- 6.9.** Rooms that utilize compactor units or trash chutes must have at least one additional container for overflow.
- 6.10.** Internal solid waste rooms either opening into an alley or having a staging area in an alley must also follow Section VII (Alley Service) of this policy.
- 6.11.** All containers must be moved by the property owner or building staff to an accessible staging area on the property (or alley where applicable) for collection.

7. ALLEY SERVICE

- 7.1.** This section applies to commercial properties which border maintained alleys. These properties may utilize the alley as a solid waste collection location,



provided the alley is accessible to collection vehicles and has through-access to streets at both ends.

- 7.2.** The alley must be clear and accessible along the entire length.
- 7.3.** The container placement must provide clearance along the width of the alley so as to not block passage of vehicles. Containers cannot protrude into the alleyway more than 42 inches or the width of a standard 3-yard dumpster.
- 7.4.** All solid waste containers must be stored along the property which they service.
- 7.5.** Enclosures are generally not required for alley service.
- 7.6.** Alley service is limited to 3 - 5-yard wheeled dumpsters, 95-gallon carts where feasible or approved compactors.
- 7.7.** Developments with alley parking garage entrances/exits or alley loaded parking must have adequate space to stage containers along property line. If there is not adequate space, an alternative solid waste staging area, approved by Public Works Solid Waste staff, must be provided.
- 7.8.** Containers cannot be placed or staged within 15 feet of a parking garage entrance/exit or fire exit.

8. LARGE CONTAINER AND LOADING DOCK

- 8.1.** This section applies to commercial developments proposing the use of compactors or roll-off containers with a capacity greater than 8 cubic yards, which require service by a specialized roll-off truck.
- 8.2.** Large compactors and roll-off containers must be located on an accessible service area (see Section IV), and out of view from public streets, unless approved otherwise.
- 8.3.** Provide adequate vehicle maneuvering space for a typical 35' long service vehicle with a minimum 65' outside turning radius.
 - 8.3.1.** A separate site plan showing drive paths is required for sites with constrained access or limited paving.
- 8.4.** Containers must be placed on a steel-reinforced concrete pad minimum 6 inches thick, designed to support 55,000–60,000 lbs. Include a reinforced apron, sized to match container footprint.
- 8.5.** Provide 60' of straight clearance in front of the container for truck approach and loading.
- 8.6.** Provide a minimum of 15' vertical clearance for all access travel lanes, 26' at the compactor or roll-off point of service (actual height may vary by equipment type).



- 8.7.** Containers may be serviced from a dock or elevated platform. Platform/Dock height must not exceed 4' to allow container to easily be removed/placed on rails of truck. Minimum vertical clearance at point of service may be reduced to 22' if container is serviced from a dock or elevated platform.
- 8.8.** Loading dock surface slope must be level (max 0.5% grade).
- 8.9.** Provide minimum 12' of width to allow truck cab door opening swing.
- 8.10.** Provide additional space for bin hopper or chute system, mechanical and electrical equipment, winches, and/or container rails to ensure safe container staging and servicing.
- 8.11.** Any leaf style gates used to access the large compactor or roll-off container must open 120 degrees minimum and have wind stops.

9. RESIDENTIAL PROPERTIES AND SUBDIVISIONS

- 9.1.** This section applies to residential subdivisions where a separate set of carts is kept with each dwelling unit, to be serviced at the curb, alley, or service drive
- 9.2.** All streets, alleys or service drives must be designed so that collection vehicles are not forced to back up at any time. A paved hammerhead turnaround may be provided for this purpose; parking is not permitted in the turn-around area.
- 9.3.** All developments utilizing residential service, including condominiums, town homes and patio homes, must provide a minimum of 15 feet of curb space per dwelling unit for the carts to be placed at the curb for collection or pay for carry-out service.
- 9.4.** Cul-de-sacs must have an unobstructed 96' minimum diameter.
- 9.5.** Alleys and service drives designated for solid waste collection shall be a minimum of 16' wide (curb-to-curb) with no parking permitted.
- 9.6.** Trees, streetlights, wiring and other overhead obstacles shall not impede solid waste collection and will be maintained to provide an 18' high clearance above the cart collection location(s).
- 9.7.** Designated parking areas shall not impede curbside solid waste collection; no parking is permitted in cul-de-sacs.
- 9.8.** Developers of gated subdivisions shall provide the solid waste hauler with access to the subdivision.
- 9.9.** Lots not accessible to collection vehicles, including flag lots, lots on dead-end streets and lots with private or shared driveways, must take their carts to the designated and accessible staging area for collection or pay for carry-out or premium carry-out service.



- 9.10. A signed service agreement is required for solid waste service on private streets.
- 9.11. If the above general requirements cannot be met, commercial service may be required.

10. WAIVERS AND APPEALS

- 10.1. Any person may request a waiver of any provision of this policy.
- 10.2. All waivers and appeals must be submitted the Public Works Solid Waste in writing.
- 10.3. Reference Boise City Solid Waste Ordinance (Sec. 10-4-5-3 and 10-4-5-4) for the waivers and appeals process.



12. DIAGRAMS

Figure 1 – 16' X 12' Enclosure, Single Dumpster with Two Carts

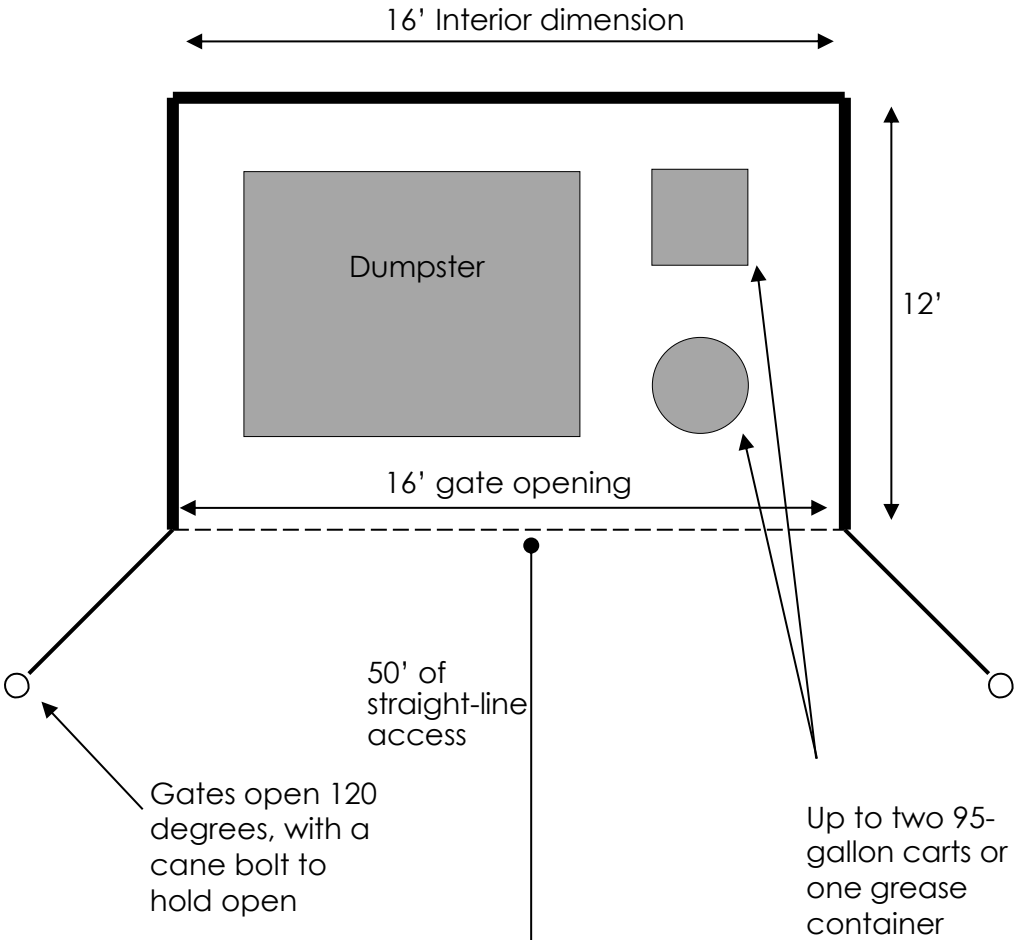

Figure 1

Figure 2 – 18' X 12' Exterior Enclosure – Two Dumpsters

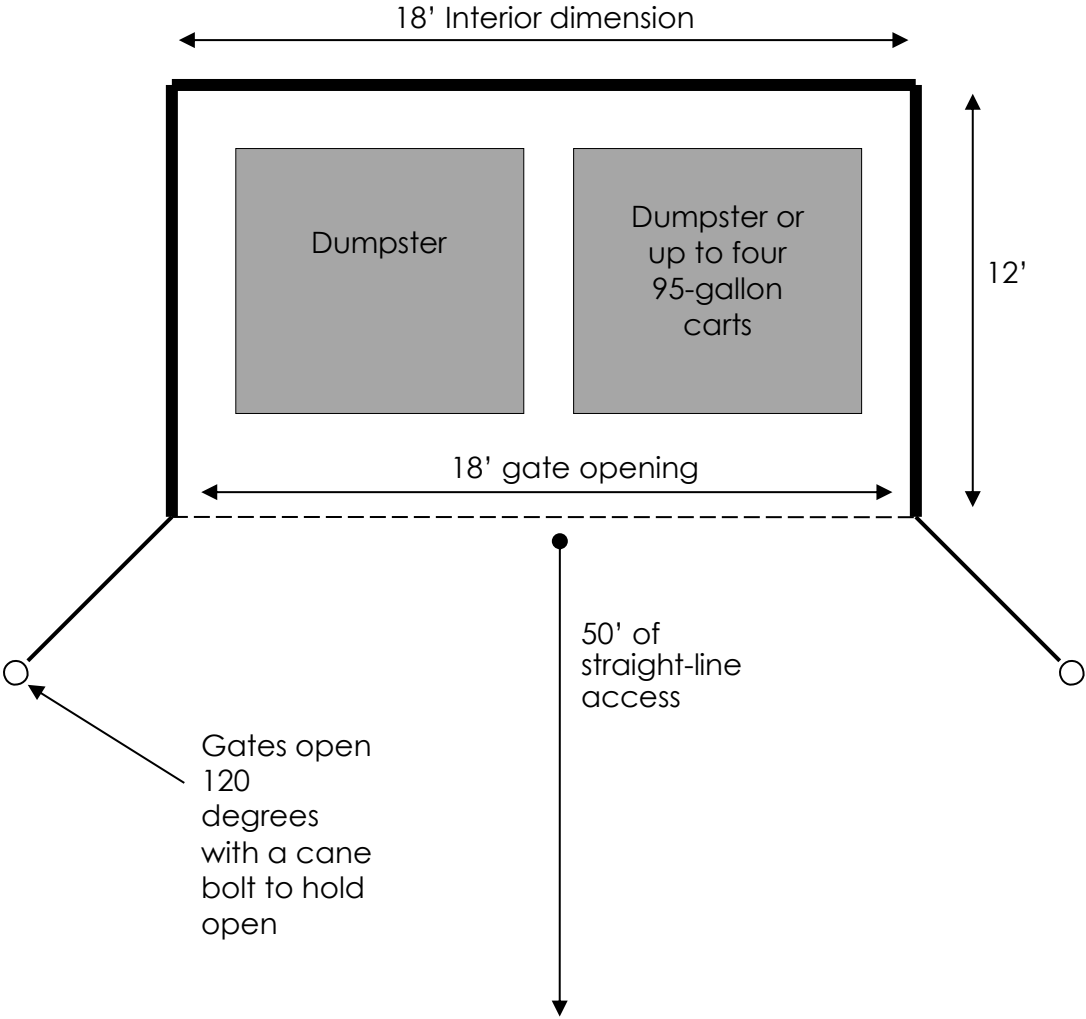

Figure 2

Figure 3 – Typical Single-Bank Cart Corral

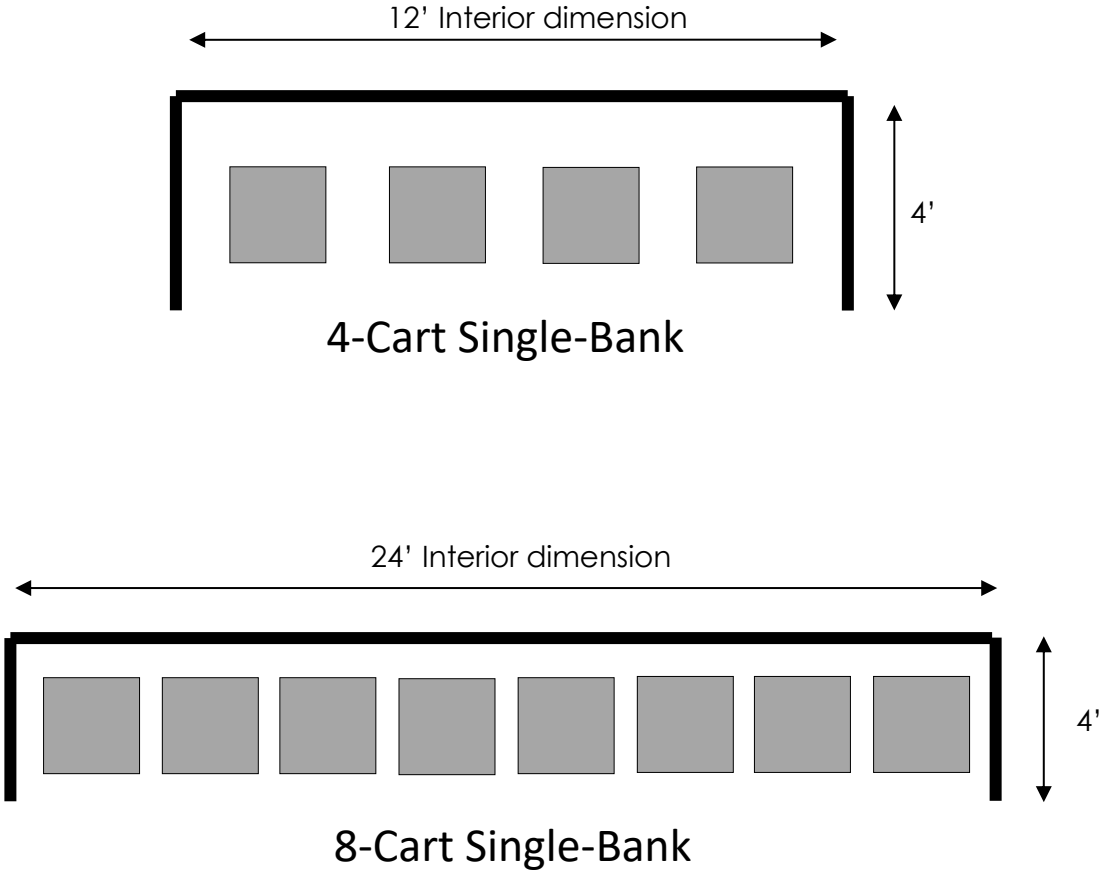

Figure 3

Figure 4 – Typical Double-Bank Cart Corral – 8 Carts

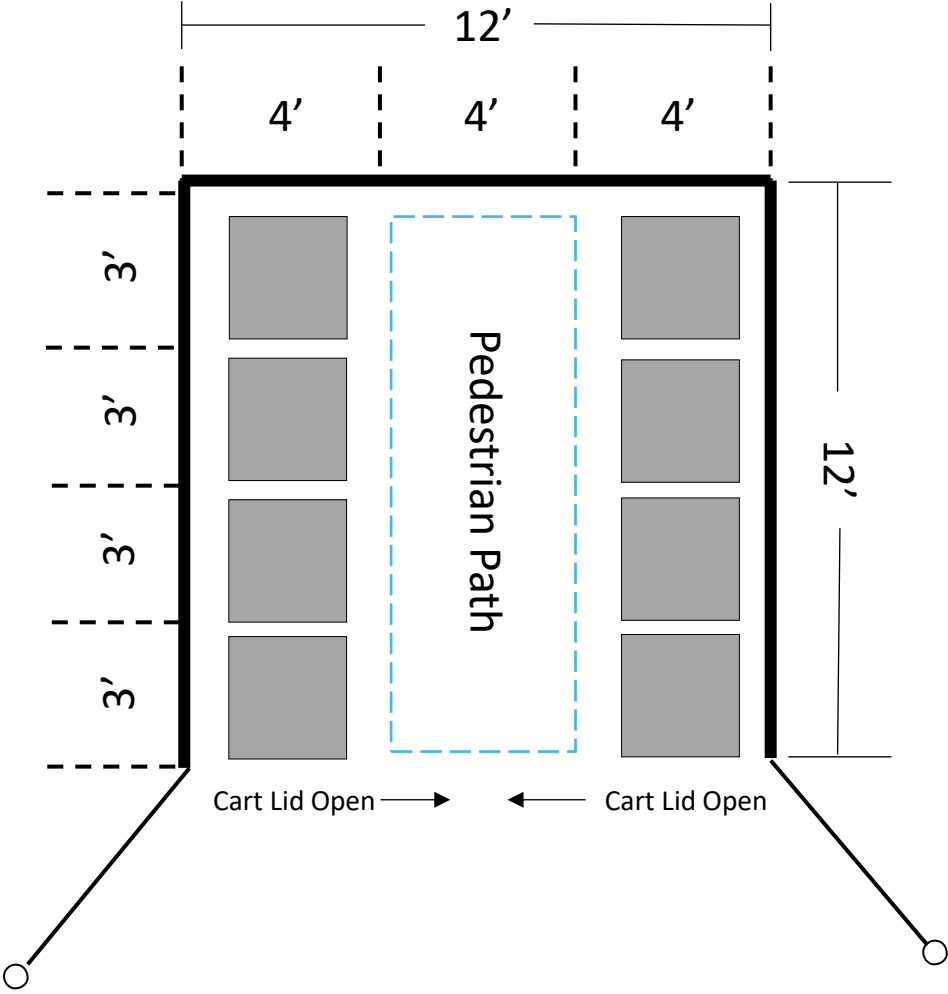

Figure 4

Figure 5 – Dual Dumpsters in Single Enclosures

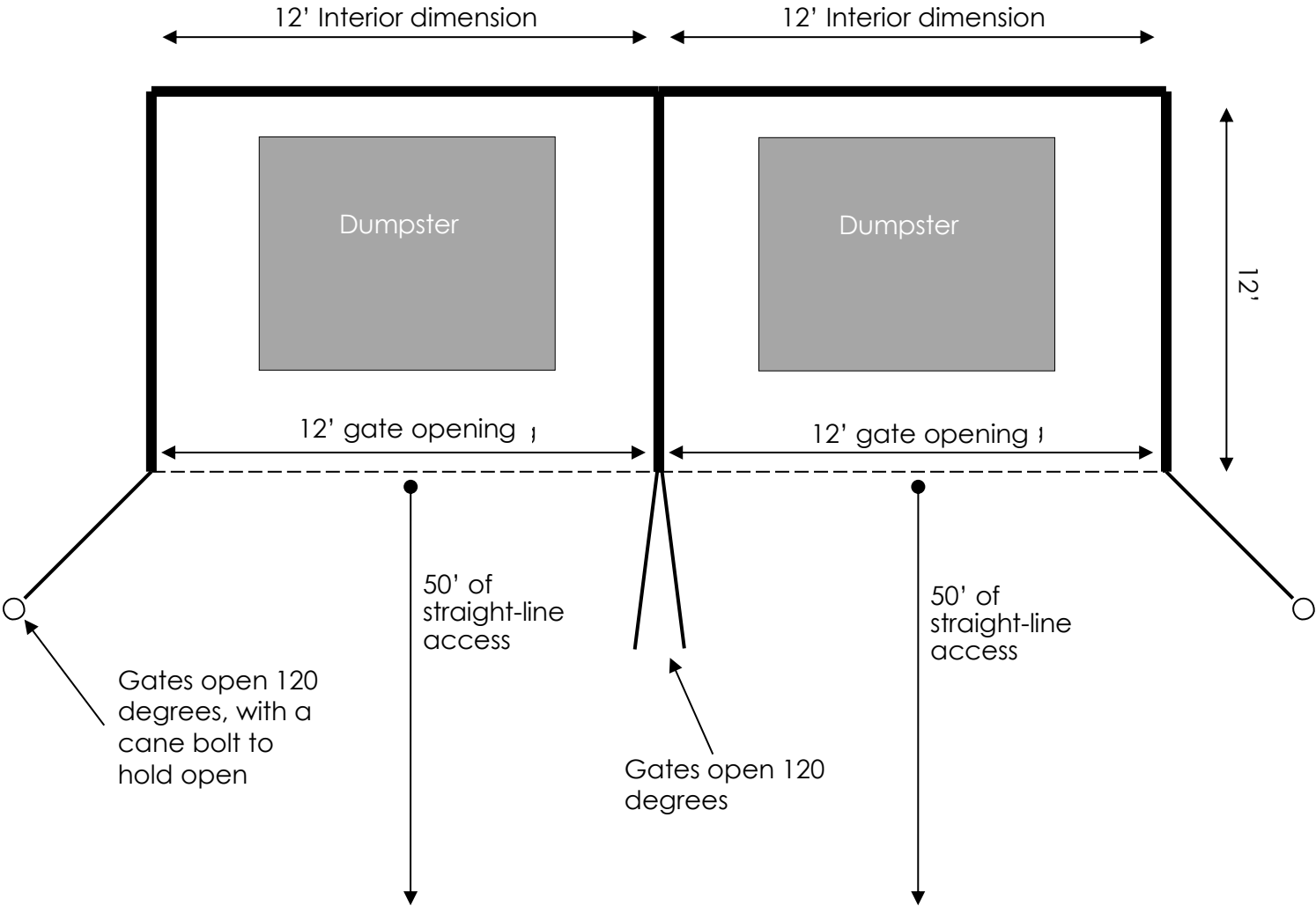

Figure 5

Figure 6 – Typical Dumpster Enclosure, Bollard, and Pedestrian Entrance Location

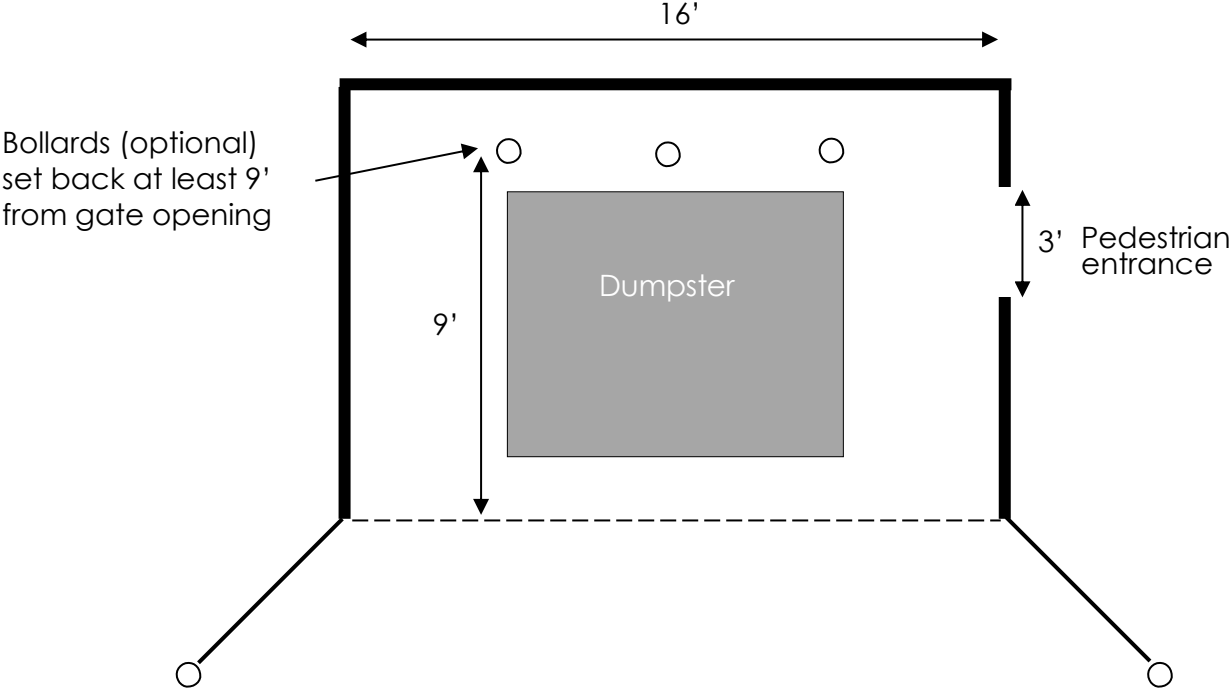
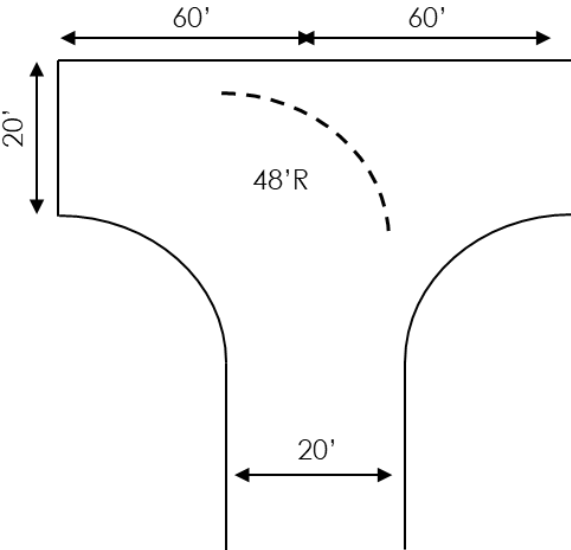
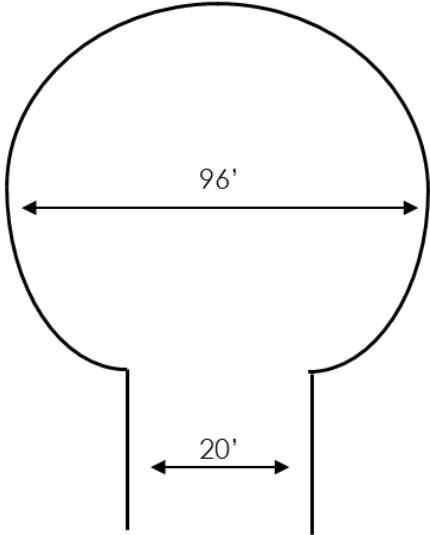

Figure 6

Figure 7 – Approved Turnaround Types



Type 1. 120' Hammerhead



Type 2. 96' Diameter Cul-De-Sac

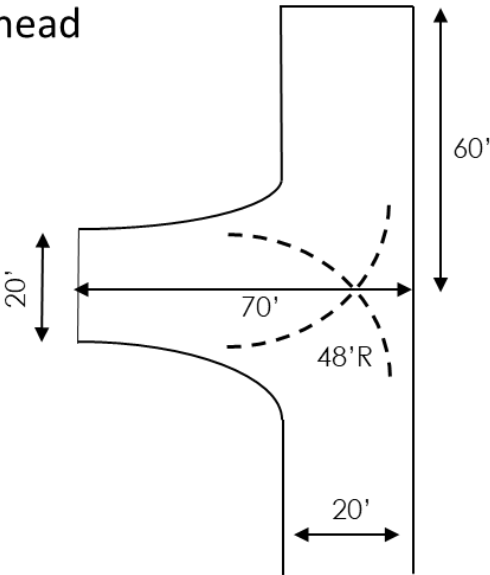

Type 3. 70' Modified Hammerhead

Figure 7

Figure 8 – Exterior Enclosure Access Examples

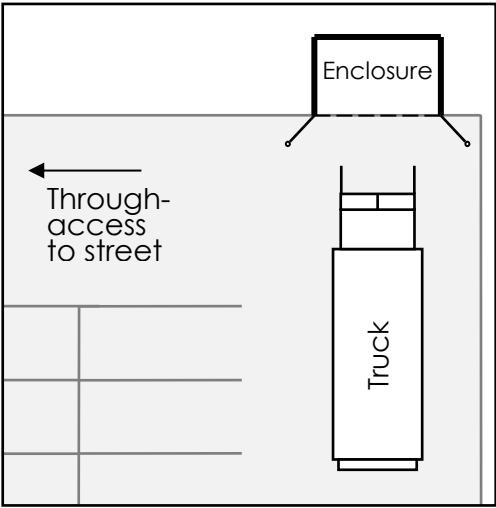

Acceptable location. Vehicle can access enclosure with minimal backing.

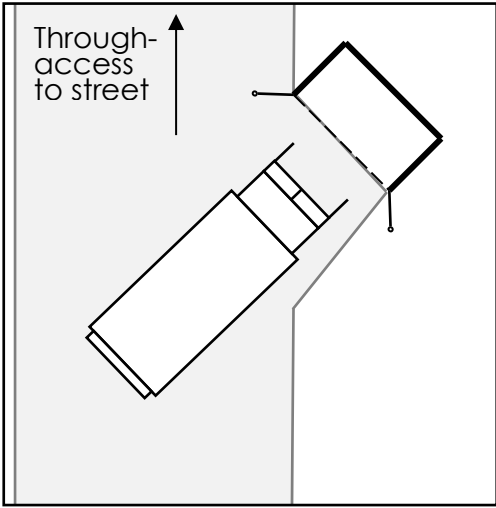

Acceptable location. Vehicle can access enclosure with minimal backing.

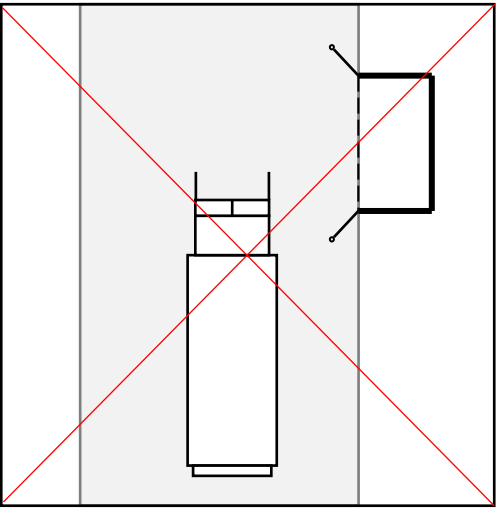

Unacceptable location (except for alley service). Vehicle does not have 50' of access in front of enclosure.

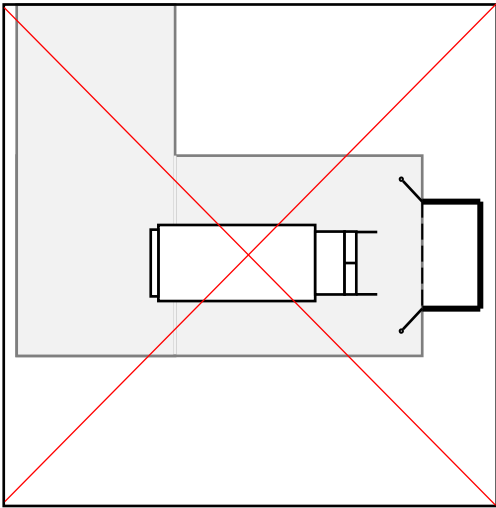

Unacceptable location. Vehicle is required to turn while backing.

Figure 8

Figure 9a – Acceptable Site Multiple Enclosure Configuration

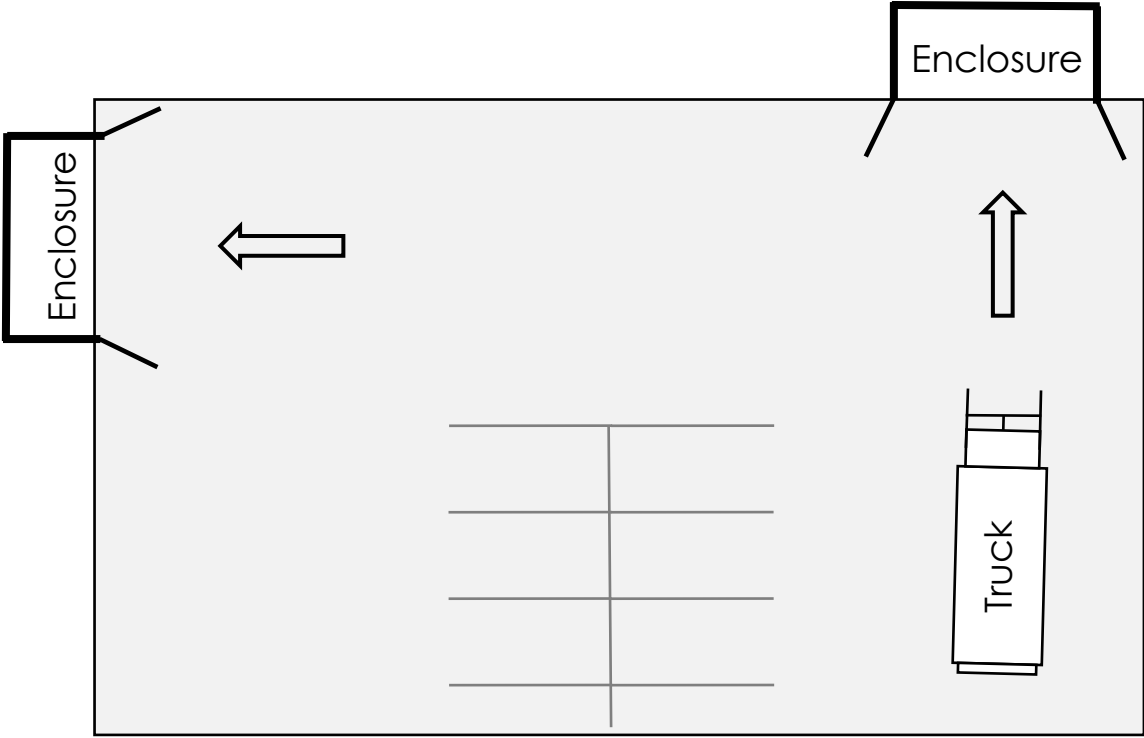

Acceptable enclosure locations. Vehicle can service both enclosures without having to exit the property to turn around.

Figure 9a

Figure 9b – Unacceptable Site Multiple Enclosure Configuration

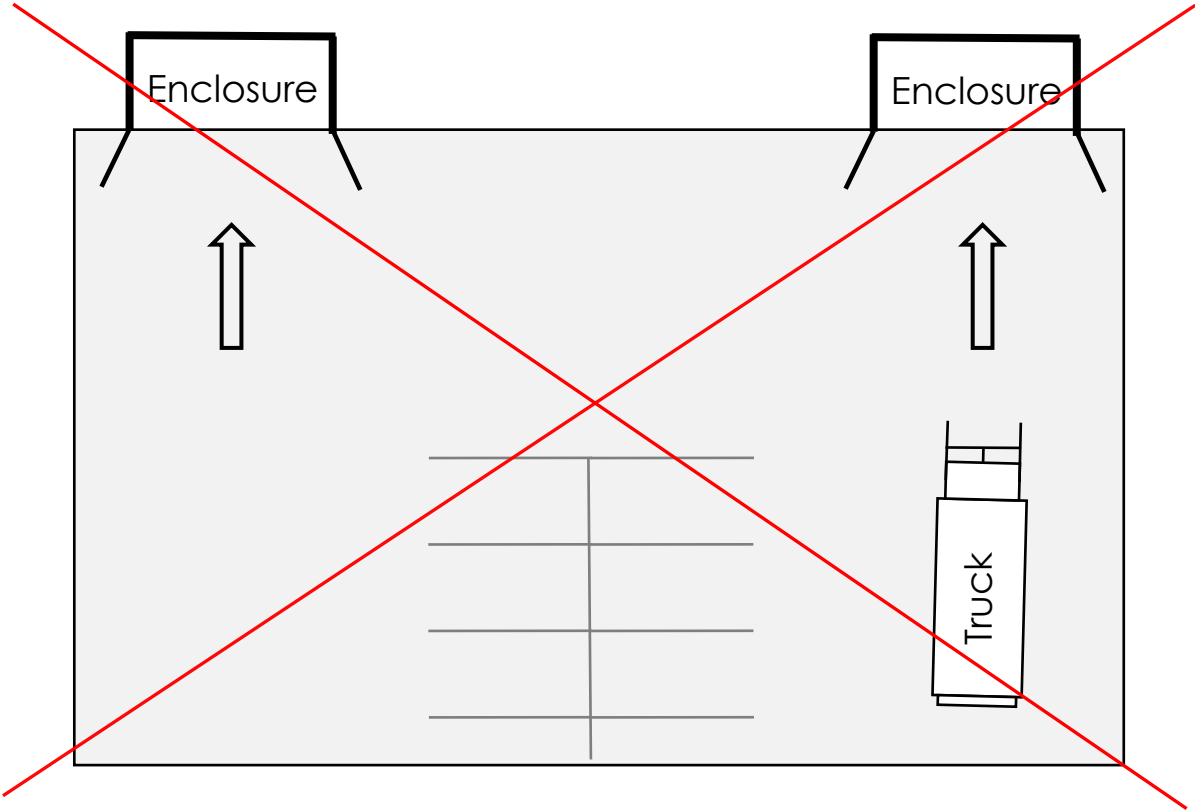

Unacceptable enclosure locations. Vehicle cannot service both enclosures without having to exit the property to turn around.

Figure 9b